



36-INCH GAS COOKTOP

HCT365GS | PROFESSIONAL STYLE



AVAILABLE MODELS

- HCT365GS/NG 36" Gas Cooktop, Silver Stainless Steel, Natural Gas
- HCT365GS/NG/H 36" Gas Cooktop, Silver Stainless Steel, Natural Gas High Altitude
- HCT365GS/LP 36" Gas Cooktop, Silver Stainless Steel, Liquid Propane
- HCT365GS/LP/H 36" Gas Cooktop, Silver Stainless Steel, Liquid Propane High Altitude

FEATURES & BENEFITS

- Illumina™ Indicator Lights for both style and peace of mind in the kitchen.
- SimmerSear™ Burner provides up to 18,000 BTU's and achieves ultralow temperatures for simmering and melting without any scorching.
- PermaClean™ Finish is an exclusive scratch-resistant, bead-blasted surface that retains a permanently beautiful finish.
- One-Piece Spill Basin ensures easy clean-up.
- Continuous Platform Grates for the optimum cooking surface for larger pots:
 - 2 - 8 1/2" Wide Continuous Platform Grates
 - 1 - 10 1/2" Wide Continuous Platform Grate
- Downdraft compatible for use in island configurations (MRV3615S)
- Smart Flame™ Technology for heat management to preserve the finish and life of the grates.
- Die Cast Knobs for durability and style.
- 4" Chassis Height for over-the-oven configurations.
- 5 Sealed (brass) with porcelain caps
 - Center, 18,000 (BTU) Brass Dual Burner (SimmerSear)
 - Left Front, 9,000 (BTU) Brass Standard
 - Left Rear, 12,000 (BTU) Brass Standard
 - Right Front, 9,000 (BTU) Brass Standard
 - Right Rear, 12,000 (BTU) Brass Standard

**Warranty: Limited, parts and labor for one year

CONTROL FEATURE S - LED B LUE

NUMBER OF KNOBS	5 KNOBS
PERMA-FLAME™ (AUTO RE-IGNITION)	YES
ERGONOMIC, ANGLED CONTROLS	YES

TECHNICAL DETAILS

CIRCUIT BREAKER (A)	15
VOLTS (V)	120
FREQUENCY (HZ)	60
ENERGY SOURCE	GAS

DIMENSIONS & WEIGHT

APPLIANCE DIMENSIONS (H X W X D) (IN.)	4" X 36" X 21"
REQUIRED CUTOUT SIZE (W X D) (IN.)	33 5/8" X 19 5/8"

ACCESSORIES (OPTIONAL)

WOK RING	AWR4
----------	------

dacor 36-INCH GAS COOKTOP

APPLIANCE DIMENSIONS

36"

A (TOP FRAME WIDTH)	36" (76.2 CM)
B (CHASSIS WIDTH)	33 5/16" (84.6 CM)
C (CHASSIS HEIGHT)	4" (10.2 CM)

Product tolerances $\pm 1/16"$ (± 1.6 mm) unless otherwise noted.

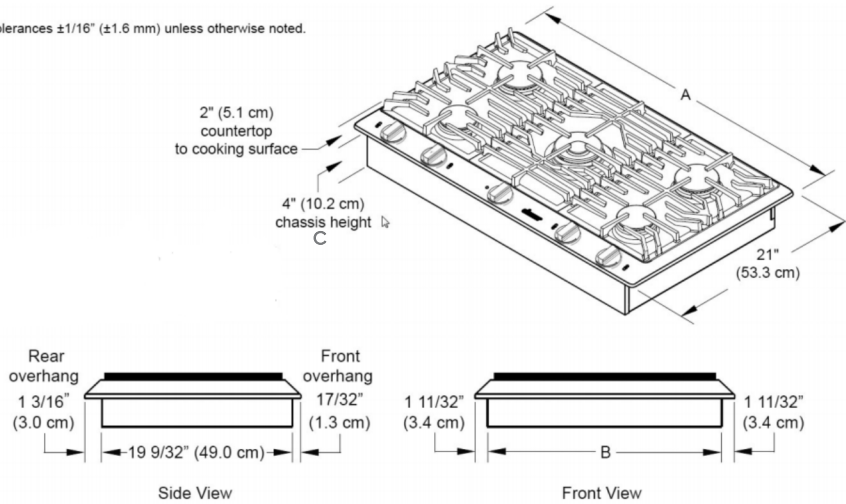

CABINET CUT-OUT DIMENSIONS

COOKTOP MODEL	C	D	E	F
HCT365GS WITH NO DOWNDRAFT VENT	3 1/4" (8.3 CM)	19 5/8" (49.9 CM)	33 5/8" (85.4 CM)	6 7/8" (17.5 CM)
HCT365GS WITH MRV3615S	3/8" (1.0 CM)	22 3/4" (57.8 CM)		

